

FROG "MINX"

30" SPAN DURATION RUBBER MODEL.

INTRODUCTION.

This model incorporates very simple constructional methods, as most of the parts can be built directly over the plan. This kit follows the usual Frog practice of supplying most of the parts cut to shape and numbered to correspond with the drawing, leaving very little shaping to be done. The pre-cut parts can be eased out of the panels with a balsa-knife, or a razor-blade broken in two to obtain a point.

Pin the drawing to a flat board to work on, and cover it with a sheet of greaseproof paper to protect it from the cement. Dope and cement are not included in this kit, but can be obtained at any model shop.

CONSTRUCTION.

FUSELAGE. This is a simple box-type structure, which can be built mainly over the plan. First build the two sides from 1/8in. square strips 1 and 2, and parts from sheet 1, as shown in Fig. 1. Duplicate the strips, and build the second side over the first, with a piece of tracing paper between them. Note the joint in the lower longerons. While these are setting, make up the bulkheads 5, 6 and 8 over the plan as shown in Fig. 4 and remove part 7 from the panel, keeping the centre part 19 for the nose-block.

Remove the side frames from the plan, and cement bulkheads 5 and 6 in place, checking over the plan view for squareness. Next cement the bulkheads 7 and 8 in place, then cement the rear ends of the fuselage together using thin elastic bands to hold them in place until they are set. Add the cross struts 9, half bulkheads 10 and 11, and stringer 12 of 1/8in. square. Figs. 2 and 3. Bend the U/C from the 18g. wire supplied, to the shape given on the drawing, the top being bent forward as shown in Fig. 5. Bind it with cotton and cement it well to the longerons and cross-struts. The strengthening gussets are cut from scrap balsa. Cement the wheel-halves together and fit them to the U/C, using washers soldered to the axles to hold them on. Cement part 13 level with the lower longerons, and 14 level with the upper ones. Cut strips 15, and cement them in place for the windscreen support, followed by the front cowling parts 16.

Cut the dowels 17 to length, and cement them against bulkheads 5 and 6. Cement the paper tube 18 against bulkhead 8 and reinforce it with gussets made from scrap balsa. Build up the under-fin from strip and cement it in place on the fuselage.

Cement the piece 19 to the back of the nose-block and check the position by fitting to the fuselage. Mark the outline of the front bulkhead, and carve the block to the shape shown in the plan and side-views. Fit it to the fuselage for final sanding, then apply a coat of dope, and fit the metal bush 21.

CABIN. It will be easier to fit this after the covering but the following method should be used. First bend the cellastoid to shape by gently creasing it where shown in the sketch. Apply cement to the top of bulkhead 5 and along the strips 16, and hold the windscreen in place until set. Then cement the sides. Cut a hole in the side windows for the dowel 17 and cement these in place.

AIRSCREW. Two blades and a slotted hub are supplied, which should be assembled as shown in Fig. 6, after checking which is the L.E. against the dotted outline on the plan. When they are set, sand-paper them to the section shown; and round off the hub. Apply a coat of dope to seal the grain and cement the plastic bush 22 in the centre hole. Balance the airscrew on the shaft, and if uneven, sand the heavier blade until the airscrew will stop in any position. It can be covered with tissue to obtain a good finish and strengthen it.

Assemble the airscrew to the nose-block with the shaft 23. This should have a hook at the rear for the elastic motor, and after assembling the nose-block and airscrew, make a loop at the front end for the free-wheel device. This is merely a length of wire screwed loosely to the propeller so that it engages with the loop on the shaft.

WINGS. Build the two halves over the plan separately. First lay the leading and trailing edge W1 and W2 over the drawing, with pins placed either side where necessary. Then cement ribs W3—W8 in place and tip pieces W9 cut from 3/8in. strip, together with gussets W10 and W11 from sheet 1. Taper the spar at the tip, and cement it in place in the rib slots. When both sides are built, and the cement has set, remove them from the plan and trim the spars to length, making a lap joint of the main spar as shown. Lay the wing-halves over the lower drawing, raise the tips 2in. and assemble the centre-section, using the strips W12 and W13 as shown, and shape them after. Sand-paper the leading edge and tips to shape, and smooth down the whole structure.

TAILPLANE. Pin down the leading edge strips T1 and jointing strips T2, cut from 3/8in. x 1/4in. Then pin down T3 and T4, followed by ribs T5—6 and tips T9, cut from 3/8in. strip. T10 and T11 are ready-cut parts on sheet 1. Cement the spar T12 in the rib slots, and taper the ends. Fit the centre gussets, and sand-paper the leading edge and tips to shape.

0 50
CAT. No.
647 FK.

FIG. 1

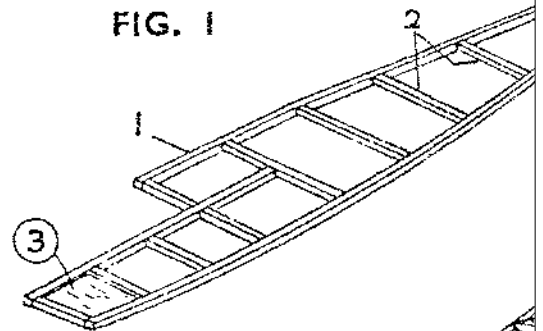

Build fuselage sides over drawing, using pins to hold parts in place.

Bend loop on end of shaft, and free-wheel latch.

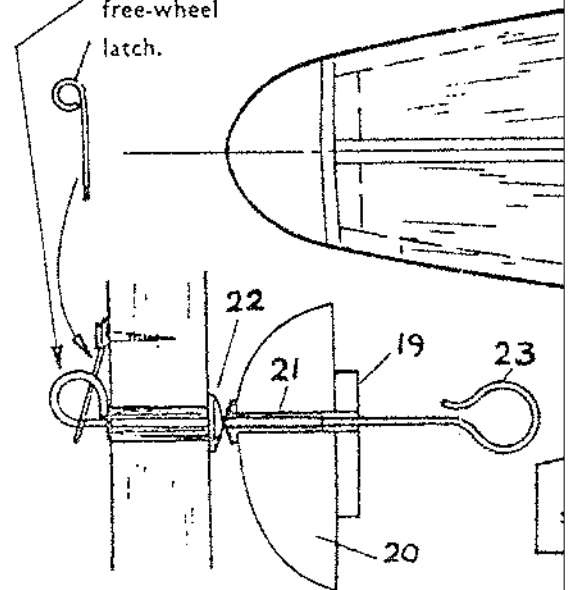

11" Airscrew

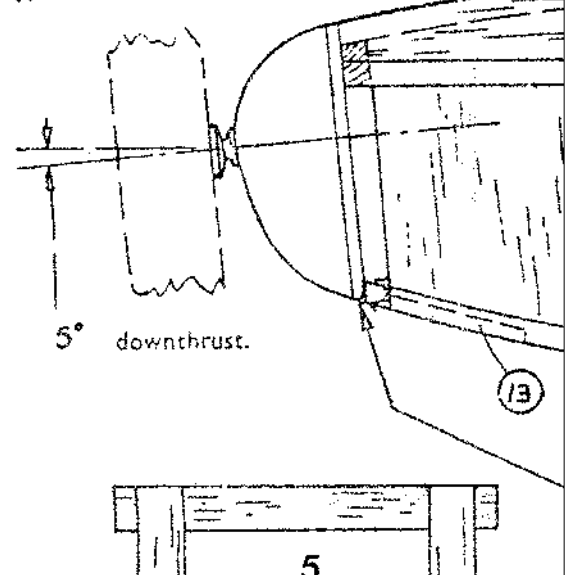

100

150

200

mm

25

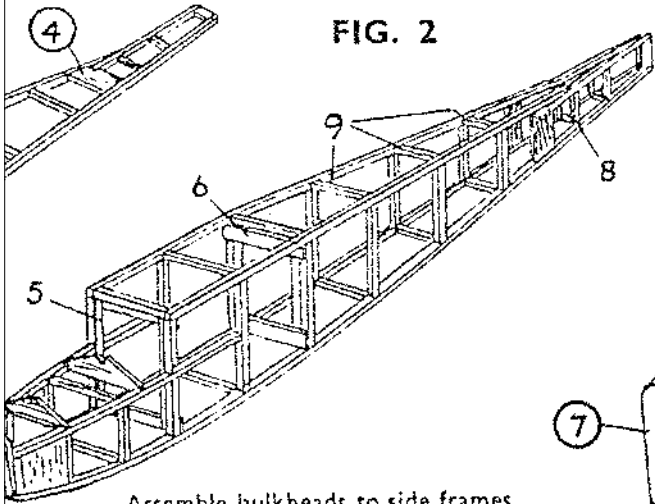

FIG. 2

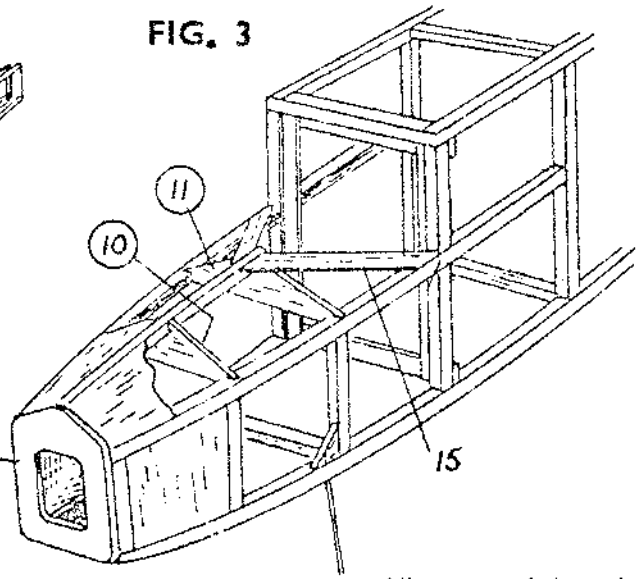
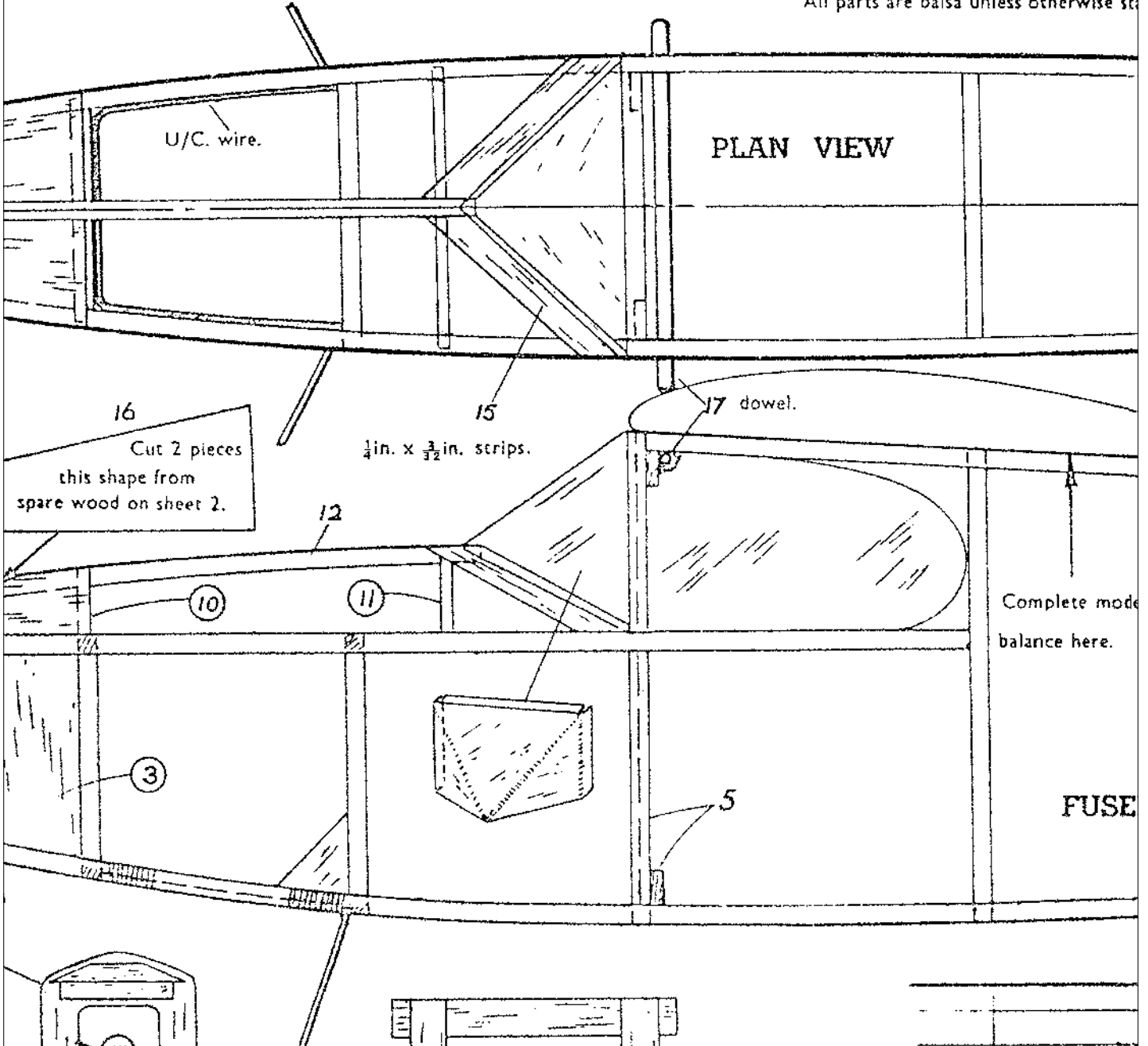

FIG. 3

Assemble bulkheads to side frames.
Place over plan to ensure symmetry.

All parts are balsa unless otherwise stated.



U/C. wire.

PLAN VIEW

16

Cut 2 pieces
this shape from
spare wood on sheet 2.

$\frac{1}{4}$ in. x $\frac{3}{16}$ in. strips.

17 dowel.

Complete model
balance here.

FUSE

250

300

350

400

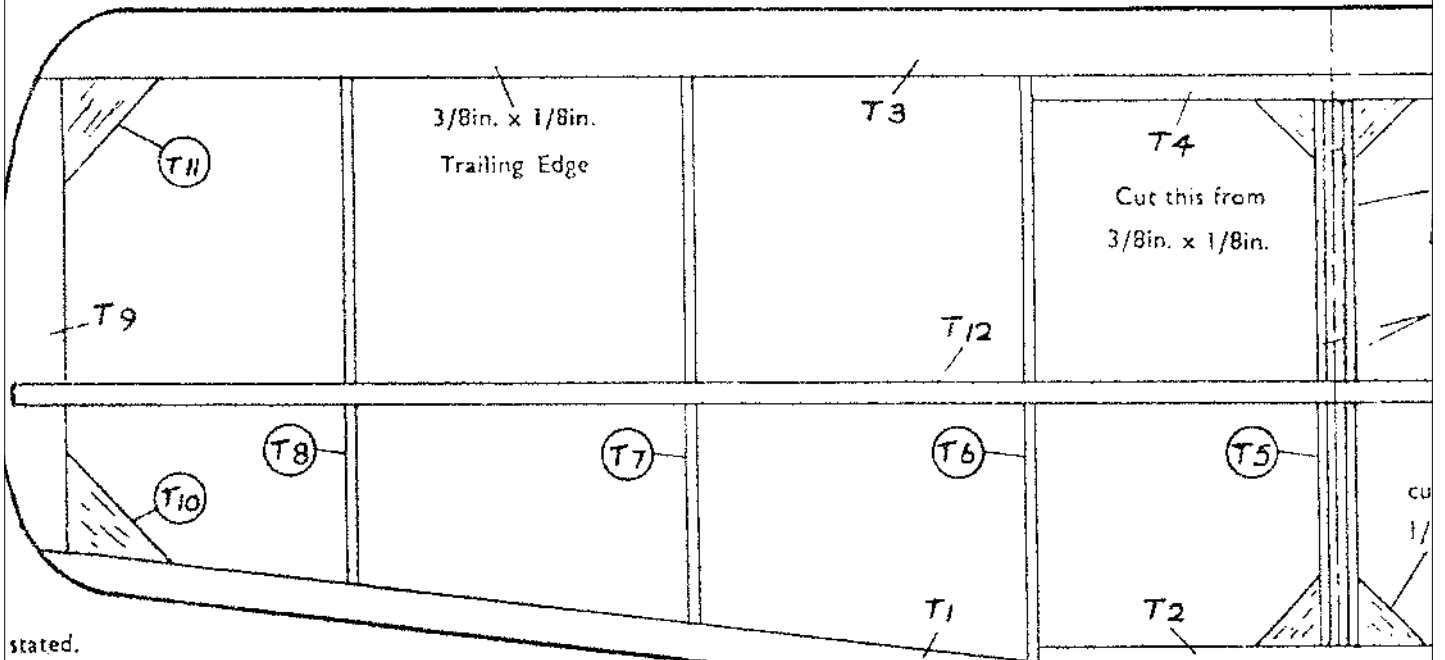

stated.

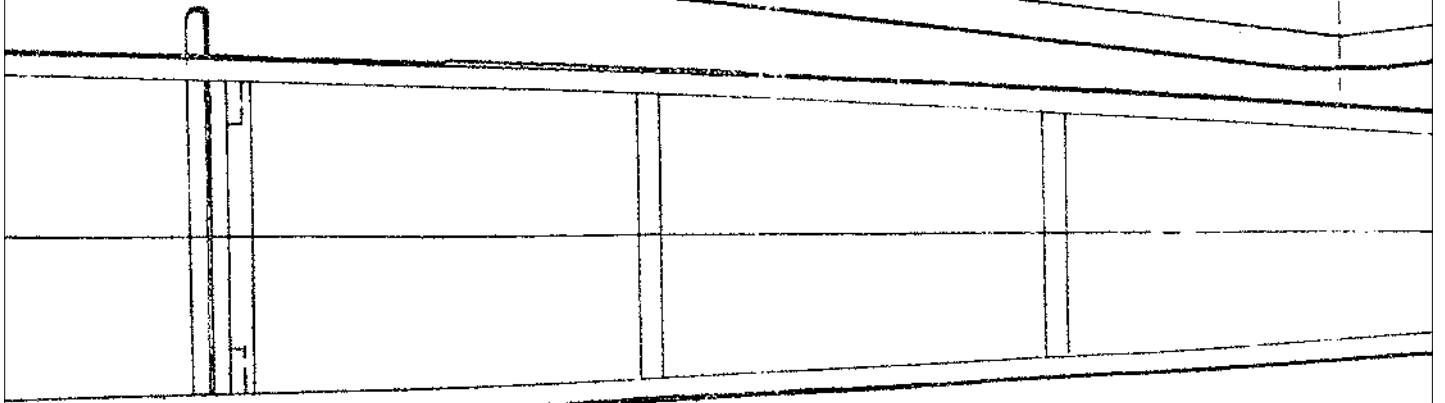

1/7 dowel.

Parts numbered thus— (4) —are pre-cut and printed on sheet balsa.

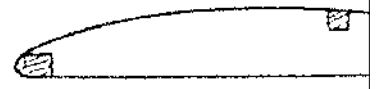

Tailplane section

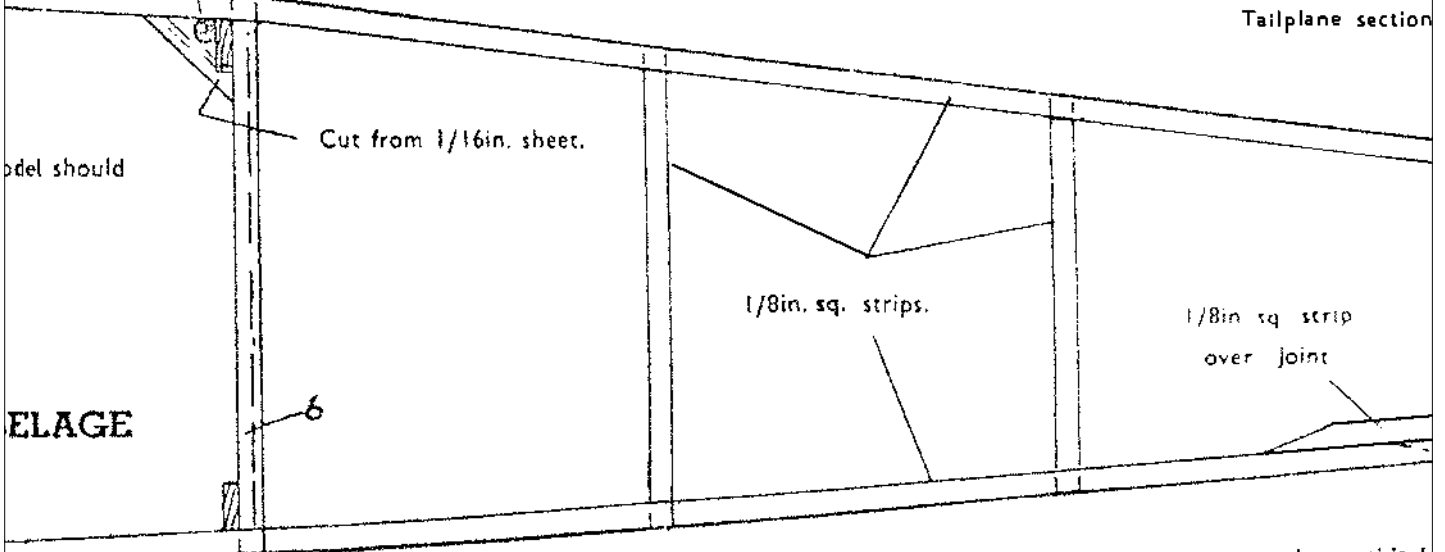

ELAGE

Leave this b
to allow access

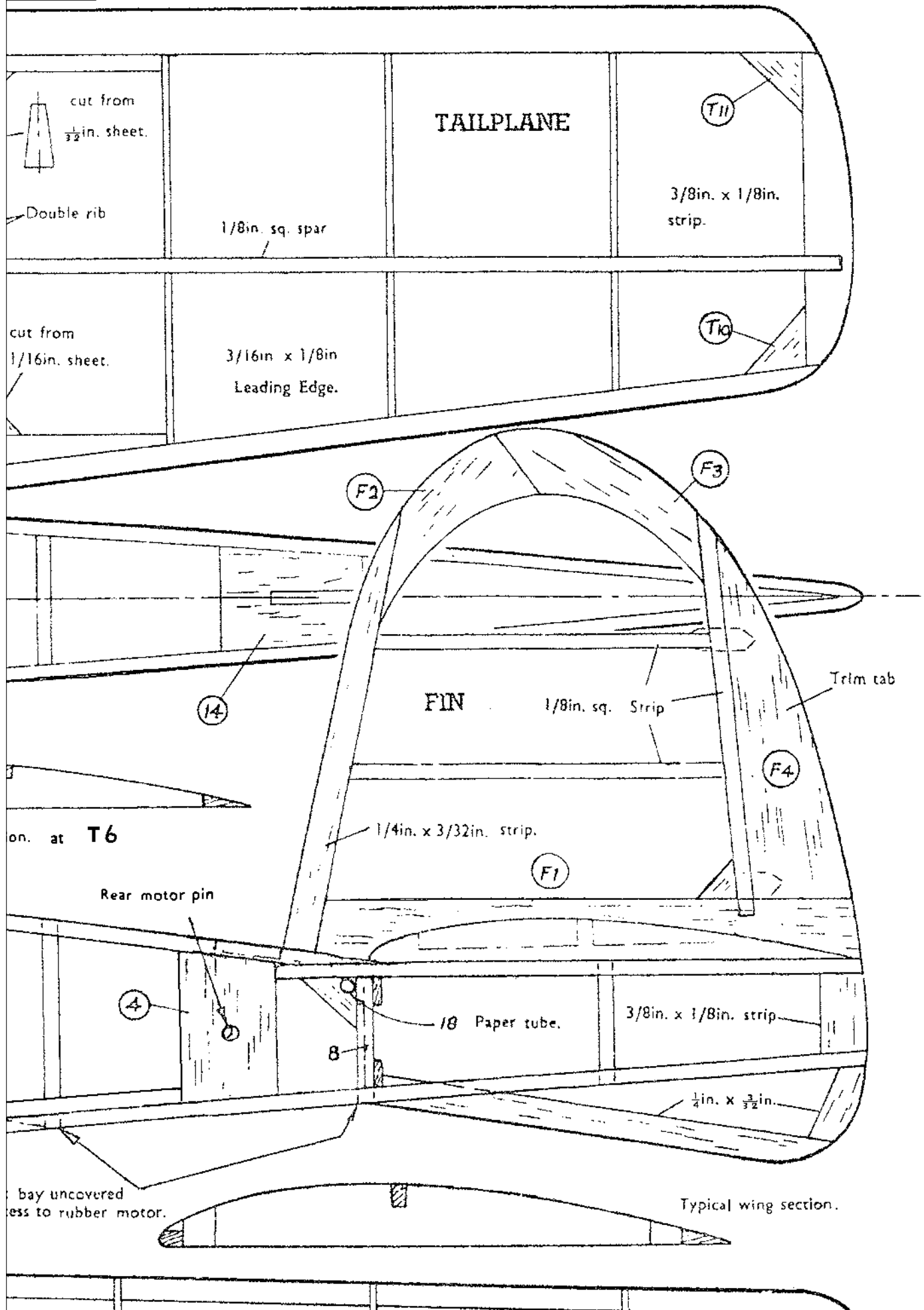

engages with the hook on the shaft.

WINGS. Build the two halves over the plan separately. First lay the leading and trailing edge W1 and W2 over the drawing, with pins placed either side where necessary. Then cement ribs W3—W8 in place and tip pieces W9 cut from 3/8in. strip, together with gussets W10 and W11 from sheet 1. Taper the spar at the tip, and cement it in place in the rib slots. When both sides are built, and the cement has set, remove them from the plan and trim the spars to length, making a lap joint of the main spar as shown. Lay the wing-halves over the lower drawing, raise the tips 2in. and assemble the centre-section, using the strips W12 and W13 as shown, and shape them after. Sand-paper the leading edge and tips to shape, and smooth down the whole structure.

TAILPLANE. Pin down the leading edge strips T1 and jointing strips T2, cut from 3/8in. x 1/4in. Then pin down T3 and T4, followed by ribs T5—6 and tips T9, cut from 3/8in. strip. T10 and T11 are ready-cut parts on sheet 1. Cement the spar T12 in the rib slots, and taper the ends. Fit the centre gussets, and sand-paper the leading edge and tips to shape.

FIN. This is built over the drawing, using parts F1—F4, and strips where shown. Raise the outline with thin card, to centre it against the 1/8in. square strips. Fit the trim-tab with aluminium strips, and sand-paper the edges of the fin to a streamlined section.

COVERING. Cover the model with the paper supplied, in the following order—fuselage top and bottom, then sides. Wing and tailplane undersurfaces, then top. Fin, each side separately. Use office paste or dope for fixing it. Cut the paper to the approx. shapes first, leaving a 1/2in. margin all round. Apply paste to the edges of the frame, then lay the tissue over it, and pull gently all round. Do not attempt to get it drum tight, but aim at getting an even surface, with no deep wrinkles. The water-spraying and doping will tighten the surface.

Before doping, lightly brush or spray each part with water and leave to dry. Spray half a wing at a time, and pin it down to a flat board to prevent warping whilst it is drying. Do the same with the tailplane. When they are completely dry, give each part a coat of dope, and pin down the wing and tailplane again, when the dope begins to dry. A coat of clear cellulose lacquer over the whole of the model is beneficial.

Painting should be restricted to the fuselage to save weight.

RUBBER MOTOR. Make up a skein of 6 strands of 1/4in. x 1/30in. strip 24in. long. This is longer than the fuselage to enable more turns to be obtained. A shorter one can be used if desired, the turns being proportionately reduced. Lubricate it with castor oil or lubricant before fitting. Loop one end on to the airscrew shaft, securing it with thread, and drop the other end down the fuselage and secure it with the dowel pin.

ASSEMBLY. Having fitted the motor and airscrew, the rest of the model can be assembled. Use two 2 1/2in. x 1/8in. elastic bands to hold the wing in place. They should be stretched diagonally over the centre-section and hooked over the dowels 17. For the tailplane, loop two 2in. x 1/16in. bands together to make one double length. Insert it through the tube 18 with a piece of wire, stretch both ends over the tail and on to the pin at the rear of the fuselage.

Check the rig of the complete model; the tailplane should be in line with the wing, and the fin upright. There should be no warps in the flying surfaces. If the balance is far from the position shown on the drawings, add ballast weight to either end to correct it.

FLYING. Choose a calm day for the first tests. It is an advantage to have a helper to hold the model whilst winding. If not, take up the slack on the motor by allowing the model to be suspended by it when winding up. Start with 100 turns on the airscrew and launch the model on an even keel. It should fly straight and level, or with a slight left turn. If it nose-dives, raise the back edge of the tailplane by cutting away the fin-base; and if it climbs too steeply and stalls, raise the front edge. A turn under power can be made or corrected by packing the nose-piece to one side or the other. A turn on the glide is made with the rudder-tab. When the trim seems right, the turns can be increased gradually to a maximum of 650. Winding the motor is less tedious with the help of a wheel-brace fitted with a hook. This engages with the shaft-hook, and allows the elastic to be stretched when winding.

Put your name and address on the model before flying.

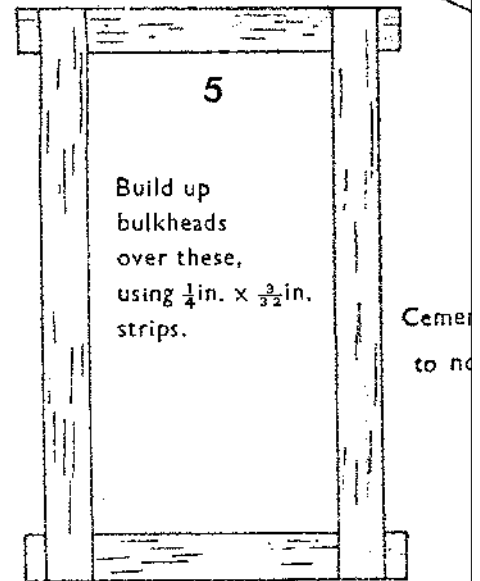
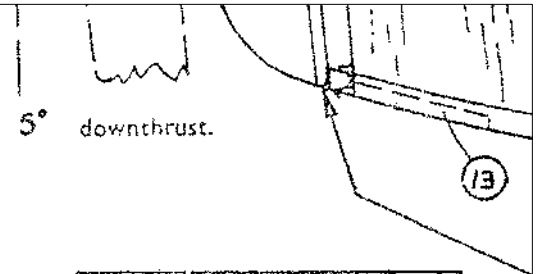
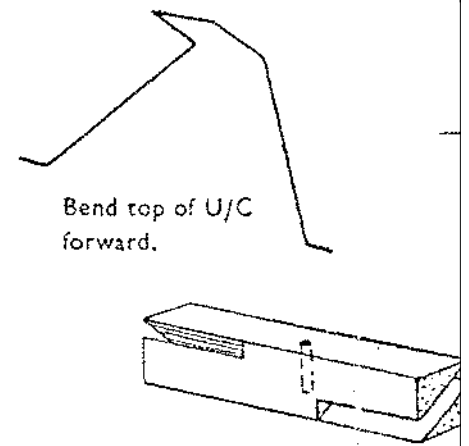
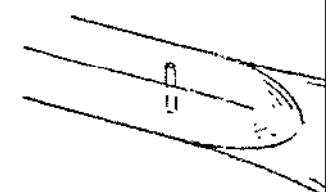

FIG. 5



Cement airscrew blades securely to hub.



Round off edges of hub.

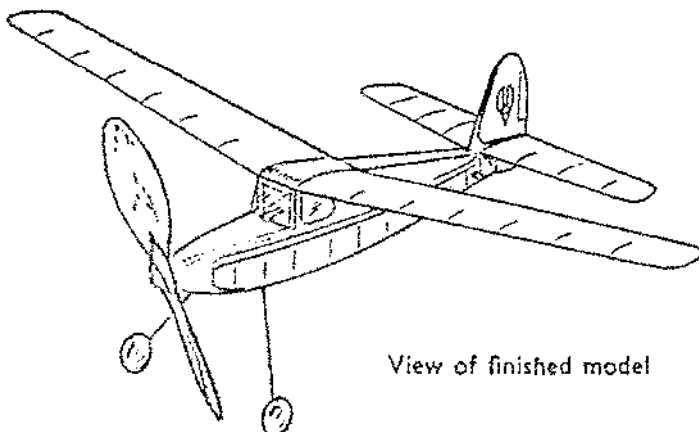

View of finished model

SPECIFICATION :

WING SPAN	...	30 ins.
LENGTH O.A.	...	24 ins.
WING AREA	...	118 sq. ins.
WEIGHT	...	3 1/2 ozs.

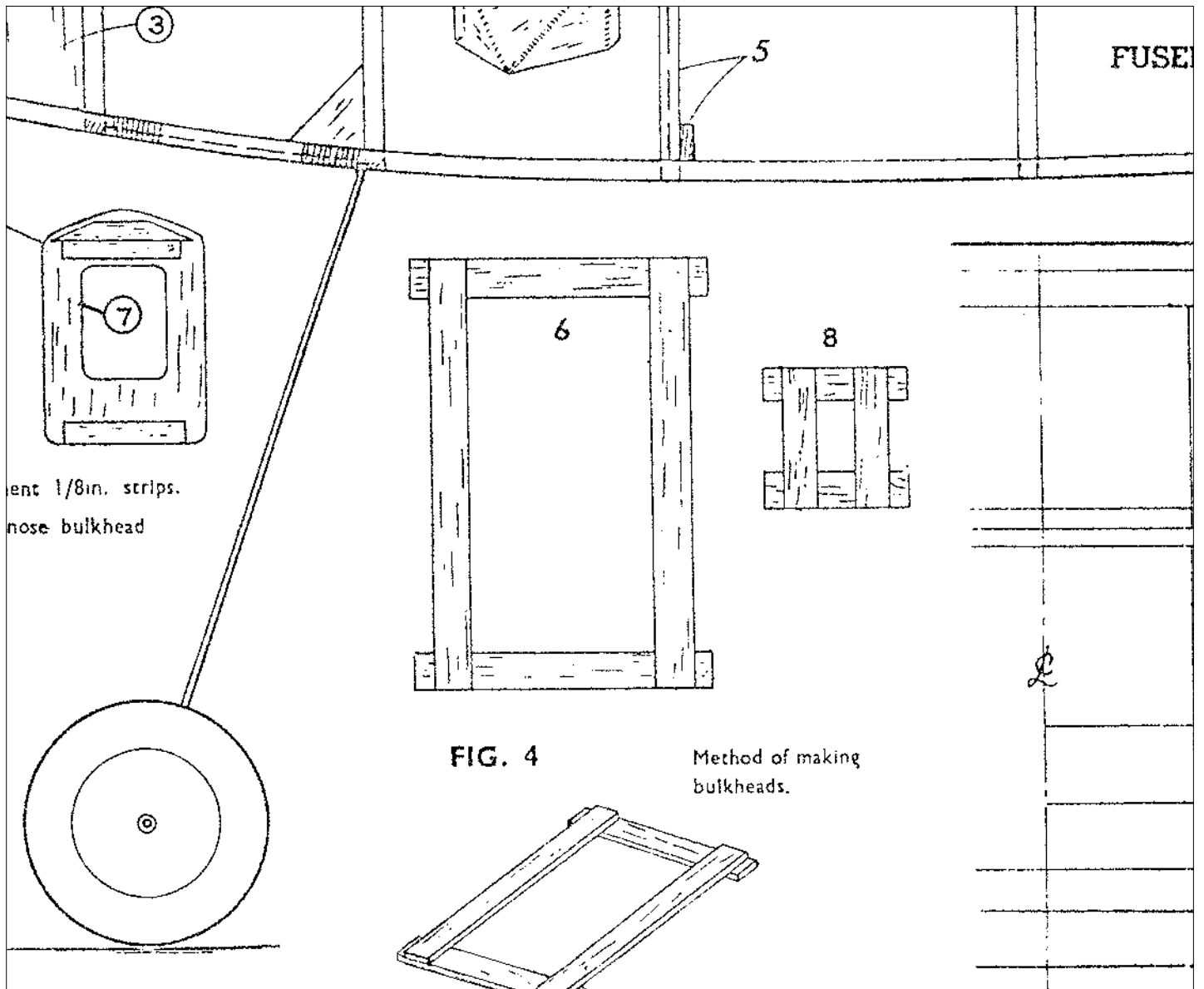

FIG. 4

Method of making bulkheads.

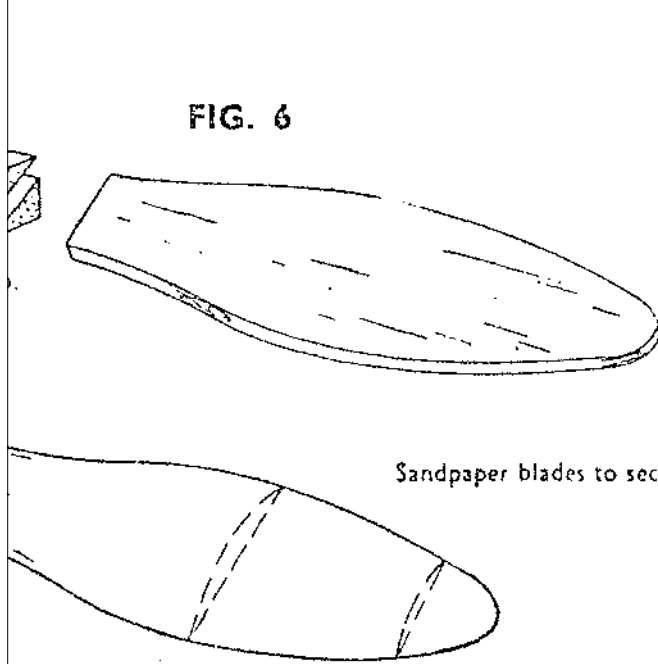
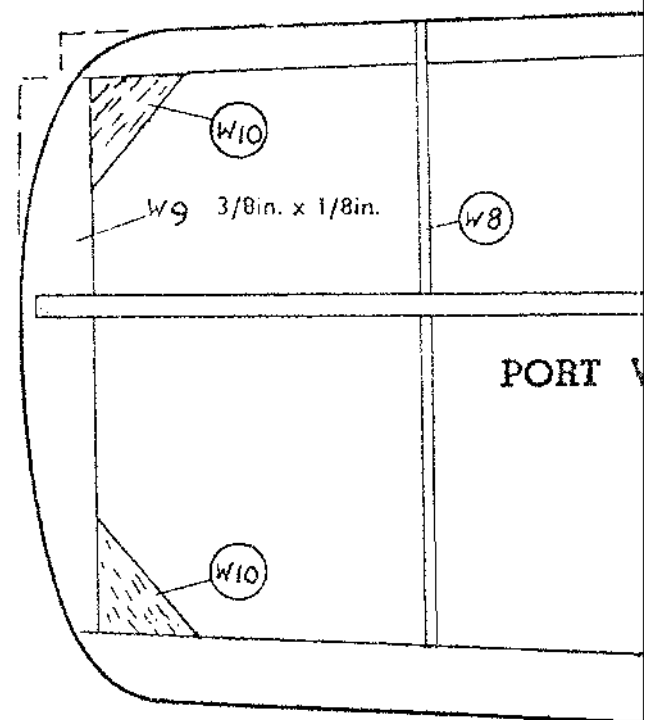

FIG. 6

Sandpaper blades to section.



Produced in England by
A. A. HALES, LTD.
 POTTERS BAR, MIDDLESEX.

Printed in England.

SELAGE

6

Leave this
to allow acce

STARBOARD

WING

Shape of U/C, wire, full-size.

w1

3/16in. x 1/8in.

Leading Edge and spar.

w11

w7

w6

w5

w

WING

3/8in. x 1/8in.

Trailing Edge

w2

